

Demonstration of Forward Collision Avoidance Algorithm Based on V2V Communication

Ahmed Hosny¹, Mohamed Yousef¹, Wessam Gamil¹, Mohamed Adel^{1,2}, Hassan Mostafa^{2,3}, M. Saeed Darweesh^{1,3}

¹Electronics and Communications Department, Institute of Aviation Engineering and Technology, Giza, Egypt

²Faculty of Engineering, Cairo University, Giza, Egypt

³University of Science and Technology, Nanotechnology Program, Zewail City of Science and Technology, October Gardens, 6th of October, Giza 12578, Egypt

Abstract—This paper proposes a hardware implementation of a Vehicle-to-Vehicle (V2V) communication-based forward collision avoidance algorithm by alarming the driver about potential crashes. The proposed system benefits from the information exchange between the host vehicle and the leading vehicle to calculate the safe distance between the host vehicle and leading vehicle to guarantee the avoidance of the collision. The proposed system gives advisory and imminent warnings according to the predicted accident levels, using three different levels of collision avoidance. This work tests a prototype implementation of a complete V2V communication, designed according to the Basic Safety Message (BSM) specification SAE J2735. The purpose of this work is to prove the feasibility of V2V to improve the safety of transportation systems. The results show that the proposed collision avoidance system makes a composite analysis of the collision risk and provides an accurate real-time warning.

Keywords— Demonstration, Hardware, Vehicle-to-Vehicle (V2V), Collision Avoidance.

I. INTRODUCTION

Automobile industry occupies a pivotal position in technological research around the world, Billions of dollars are spent yearly on the field of research and development of cars capacities either in terms of luxury or safety. This opens the way for many of global corporations to invest Billions of dollars every year into research for the huge financial revenue and technological gains in favor of the corporations and economies around the world.

Safety element in cars is a basic pillar in the reduction of accidents around the world. According to the World Health Organization (WHO) 2016 statistics, 1.25 Million deaths worldwide were caused by car accidents [1], meaning that car accidents are the ninth leading cause of death around the globe, and the number is expected to rise to 1.9 Million by 2030, meaning that car accidents will be the fifth leading cause of death around the globe by 2030 [2]. This paper main objective is to reduce accidents resulting from driver error or road problems by avoiding the forward collision.

This work develops a forward collision avoidance algorithm that warns the driver to avoid a forward collision that may be caused by another vehicle. Also, this work provides practical implementation of this algorithm by using Raspberry Pi as the On-Board Unit (OBU) and Python as the scripting language.

The paper is organized as follows: Section II gives descriptions of the proposed forward collision algorithm. Section III describes the technology implementation. The hardware

implementation of V2V communication system prototype is given in Section IV. The results are given in Section V. Finally, the whole work is concluded in Section VI.

II. PROPOSED FORWARD COLLISION ALGORITHM

In this paper, the system model is based on three scenarios including the duality between the autonomous mode system and the warning system for the driver mode. The basic scenario contains two vehicles which are Leading Vehicle (LV) and Following Vehicle (FV). Every vehicle is provided by Global Positioning-System (GPS) device and Radio Frequency (RF) [3]. Antenna System is used to transfer positioning data between LV and FV and is used in couple of autonomous and warning system that uses Basic Safety Message (BSM).

According to the Society of Automotive Engineers (SEA J2735) protocol [4], the BSM is the primary message set that contains the basic information to secure the driver life and to send data among vehicles [5].

The Following vehicle updates the safe braking distances as a function of the speed, latitude, and longitude (position values). Using this information combined with the data received from the BSM sent by Leading Vehicle, the host vehicle calculates the Distance-To-Collision based on the acceleration (DTCa) between the two vehicles [6].

DTC is frequently used in literature as a descriptor of how urgent a situation has become, as well as potentially how a driver perceives stimuli during an event [7]. DTC is determined using various measures and theories. In an event that includes an FV and LV and when the LV is moving at a constant rate (zero acceleration), the DTC is computed based on the velocity only [8] as follows:

$$DTC = \frac{-r}{V_r} V_{fv} \quad (1)$$

Where r is the range between the vehicles based on the Haversine formula [7], and V_r is the relative velocity, which is defined as:

$$V_r = V_{lv} - V_{fv} \quad (2)$$

Where V_{lv} and V_{fv} are the speeds of the LV and the FV, respectively.

This paper proposes a dual mode forward collision avoidance system (driver mode and autonomous mode) based on the acceleration to be more practical and realistic model by calculating the DTCa when the FV acceleration is assumed to be zero and when the LV is decelerating. The LV acceleration is included in the equation of DTCa as follows:

$$DTC_a = \frac{-v_r - \sqrt{v_r^2 + 2a_{lv}r}}{a_{lv}} V_{fv} \quad (3)$$

Where a_{lv} and $\frac{-v_r - \sqrt{v_r^2 + 2a_{lv}r}}{a_{lv}}$ are the acceleration of the LV, and the time-to-collision, respectively.

In this paper there are three levels of thresholds defined for the warning distances considering the speed and acceleration of both vehicles (LV and FV) and the distance between them to calculate DTCa from (3). Warnings are triggered when the distance between the two vehicles are less than these defined thresholds.

The First threshold warning distance D_{w1} is calculated from (4):

$$D_{w1} = 0.5\left(\frac{v_{fv}^2}{a_{fv}} - \frac{v_{lv}^2}{a_{lv}}\right) + t_d V_{fv} + D_o \quad (4)$$

Where a_{fv} and a_{lv} are the accelerations of the LV and the FV, respectively. The additional term D_o is the distance between the host and the leading vehicle when they stop, it is used to inform the driver that there is a vehicle on the same lane.

The second threshold warning distance D_{w2} calculated from (5) and it warns the driver to take a decision to change the lane (autonomous) or to decelerate the vehicle (driver mode).

$$D_{w2} = \frac{v_{fv}^2}{19.6\left(\frac{a_{fv}}{g} + f + G\right)} + t_d V_{fv} + D_o \quad (5)$$

Equation (5) is commonly used in road design for establishing the minimum stopping sight distance required on a given road according to the American Association of State Highway and Transportation Officials (AASHTO) which gives the formula for calculating the stopping distance [9]. If the actual vehicle spacing drops below this threshold, then the distance-to-collision is less than the total distance travelled by the vehicle during the delay time (t_d) then the third threshold warning distance will be activated.

According to the second equation of motion [10], this work proposed forward collision avoidance system by proposing the equation of the third threshold warning range in an LV situation after adding the acceleration as:

$$D_{w3} = V_{fv}t_d - 0.5a_{lv}t_d^2 + D_o \quad (6)$$

The third threshold warning range warns the driver urgently to take a decision to avoid the collision immediately. In case of no-response from the driver, the autonomous mode makes the car brake or change the lane if there is no coming car in the opposite lane.

At every incoming BSM, the algorithm checks the difference between the DTCa and the warning distances (D_{w1} , D_{w2} , and D_{w3}) then calculates the time interval to reach the warning distance considering the current speed. If the obtained time to warning (t_w) is smaller than the GPS update period (t_{GPS}), a collision warning is triggered after t_w seconds.

Algorithm 1 shows the proposed forward collision algorithm.

Algorithm 1: Proposed Forward Collision Algorithm

Input: GPS update period (t_{GPS}), Distance to collision regarding acceleration ($DTCa$), Safe and automatic braking distances (D_{w1} , D_{w2} , D_{w3}) and Host vehicle current speed (V_{fv}).

Output: Time to warning (t_{w1} , t_{w2} , or t_{w3}) **begin**

$$\Delta D_1 \leftarrow DTC - D_{w1}$$

$$\Delta D_2 \leftarrow DTC - D_{w2}$$

$$\Delta D_3 \leftarrow DTC - D_{w3}$$

$$t_{w1} \leftarrow \Delta D_1 / V_{fv}$$

$$t_{w2} \leftarrow \Delta D_2 / V_{fv}$$

$$t_{w3} \leftarrow \Delta D_3 / V_{fv}$$

if $t_{w3} \leq t_{GPS}$ **then**

return (t_{w3})

else if $t_{w2} \leq t_{GPS}$ **then**

return (t_{w2})

else if $t_{w1} \leq t_{GPS}$ **then**

return (t_{w1})

end

end

III. TECHNOLOGY IMPLEMENTATION

To generate and send a BSM, a device must know its own position (such as via a GPS antenna and receiver). Once its position is known, the device needs a computer processing unit that can take its location and can combine it with other onboard sensors (e.g., speed, heading, acceleration, braking) to generate the required BSM data string. Once the BSM is generated, a device needs to transmit this message wirelessly to another vehicle. As the onboard processor is generating the BSM, a security module is processing and preparing the security information and certificates for transmission to provide the receiving vehicle assurance that the message is valid. This security information needs to be transmitted wirelessly as well. To receive and interpret a BSM, a device must be capable of receiving the BSM that is transmitted from a nearby device and it must match the method of BSM transmission (i.e., if the message is transmitted via RF, the receiving device must have an RF receiver). It also must have an assembly that can decode the BSM properly. A GPS antenna and receiver are needed to verify the relative distance between the sending device and the receiving device. The BSMs follow SAE J2735 standard frame structure. SAE J2735 is intended to address the purpose so that all V2V safety applications are built around a common

framework. SAE J2735 defines the design specifications for the safety messages, including specifications for the message sets, data frames, and data elements.

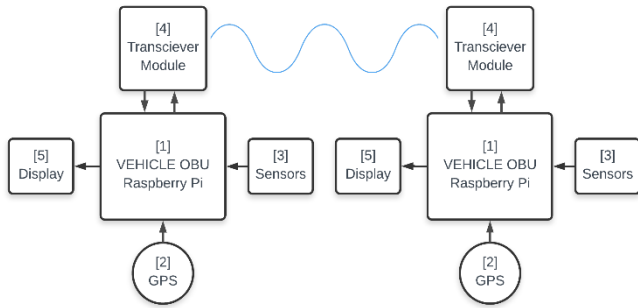

Fig. 1. V2V communication system prototype block diagram

IV. HARDWARE IMPLEMENTATION

The block diagram of V2V communication system prototype is shown in Fig. 1. GPS module provides information about speed, the location of the vehicle, and the path of the vehicle to the OBU. A prototype of V2V communication system is implemented in which, we have chosen Raspberry PI as an onboard unit, which processes the data provided by GPS as shown in Fig. 2. It generates the safety messages depending on the position of the vehicles. The safety messages are transmitted and received by the RF transceiver module as depicted in Fig. 1. Basic safety messages are displayed on the display unit. In general, two sets of components are needed for V2V communication to operate. The first set of components are those required for a device to transmit an accurate and trusted basic safety message. While the second set are the components needed for a device to receive and interpret a BSM transmitted from another entity.

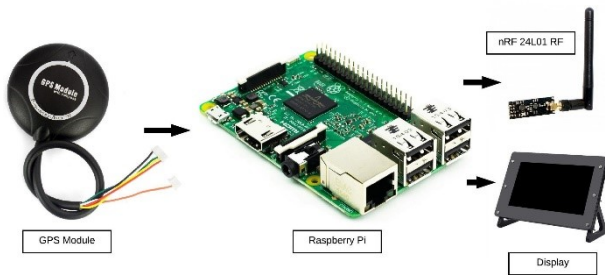

Fig. 2. Hardware architecture of V2V communication system prototype

V. DEMONSTRATION RESULTS

In this work, the prototype is tested with real vehicles to verify the performance of the proposed forward collision avoidance algorithm. The vehicles used in the practical test is shown in Fig. 3.a and Fig. 3.b. Also, the system setup inside the following vehicle and the leading vehicle is shown in Fig. 4. and Fig. 5, respectively.

The performance metric in this work is the success of generating a warning message for the driver to decelerate or brake or change the lane before the collision occurs.



Fig. 3.a. Renault Duster (Leading Vehicle)



Fig. 3.b. Gelly EM-Grand (Following Vehicle)



Fig. 4. System setup inside the following vehicle

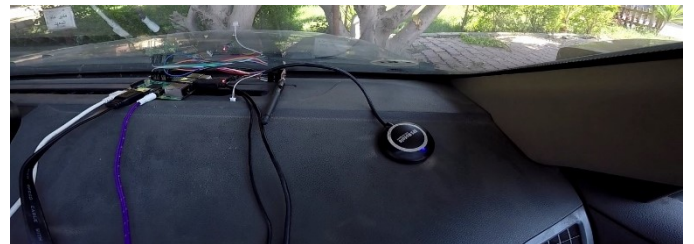

Fig. 5. System setup inside the leading vehicle

When the distance DTC between the leading vehicle and following vehicle is less than D_{w1} but still greater than D_{w2} (the first warning range), a blue warning pops up on the display and a sound plays through vehicle's speakers to warn the driver that there a vehicle is in front as shown in Fig. 6.



Fig. 6. The first warning level (Blue)

As the following vehicle gets closer to the leading vehicle and the distance DTC is now less than D_{w2} but still greater than D_{w3} (the second warning range), a yellow warning pops up and again a sound plays to warn the driver that he is approaching the leading vehicle as shown in Fig. 7.



Fig. 7. The second warning level (Yellow)

When the following vehicle becomes critically closer to the leading vehicle as the distance falls below D_{w3} (the third warning range), a red warning pops up with a sound telling the driver that he must break immediately to avoid the collision as shown in Fig. 8.



Fig. 8. The third warning level (RED)

VI. CONCLUSION

In this work, a proposed forward collision avoidance algorithm based on the vehicle acceleration which is used for warning the vehicle driver by three warning levels. The proposed algorithm

has been tested practically by implementing a hardware prototype to ensure the ability to avoid the collision in the forward collision scenario. The main computations of this work showed that the vehicle avoids the collision with another vehicle in real life.

The future work will concentrate on improving the hardware system by implementing the same system with Radar or LIDAR.

ACKNOWLEDGMENT

This work was performed on a project at Institute of Aviation Engineering and Technology (IAET) funded by the Academy of Scientific Research and Technology (ASRT). This research was partially funded by ONE Lab at Cairo University and Zewail City of Science and Technology.

REFERENCES

- [1] "Road traffic deaths," in World Health Organization, [online] Available: http://www.who.int/gho/road_safety/mortality/en/
- [2] Christopher J.L. Murray and Alan D. Lopez, eds., "The Global Burden of Disease: A Comprehensive Assessment of Mortality and Disability from Diseases, Injuries, and Risk Factors in 1990 and Projected in 2020," *Harvard School of Public Health, Boston*, 1996.
- [3] Mohamed Saeed, Hanan Kamal, Mona El-Ghoneimy, "Novel Type-2 Fuzzy Logic Technique for Handover Problems in a Heterogeneous Network," *Engineering Optimization Journal*, 2017, DOI: 10.1080/0305215X.2017.1402012.
- [4] SAE Std. J2735 SAE Int., DSRC Committee, "Dedicated Short Range Communications (DSRC) Message Set Dictionary," Nov. 2009.
- [5] H. Fahmy, G. Baumann, M. Abdel Ghany, and H. Mostafa, "V2V-Based Vehicle Risk Assessment and Control for Lane-Keeping and Collision Avoidance", in *IEEE International Conference on Microelectronics (ICM 2017)*, Beirut, Lebanon, pp. 61-65, 2017.
- [6] M. Yousef, A. Hosny, W. Gamil, M. Adel, H. M. Fahmy, S. M. Darweesh, and H. Mostafa, "Dual-Mode Forward Collision Avoidance Algorithm Based on Vehicle-to-Vehicle (V2V) Communication", in *IEEE International Midwest Symposium on Circuits and Systems (MWSCAS 2018)*, Windsor, Ontario, Canada, pp. 739-742, 2018.
- [7] F. Ivis, "Calculating geographic distance: Concepts and method," 2006. [Online]. Available: <http://www.lexjansen.com/nesug/nesug06/dm/>.
- [8] Knipling, R., Mironer, M., Hendricks, D., Tijerina, L., Everson, J., Allen, J., & Wilson, C., "Assessment of IVHS countermeasures for collision avoidance: Rear-end crashes," *DOTHS-807-995. Washington, DC: National Highway Traffic Safety Administration*, 1993.
- [9] American Association of State Highway and Transportation Officials. "A Policy on Geometric Design of Highways and Streets," 2001.
- [10] R.G. Lerner, G.L. Trigg, *Encyclopedia of Physics* (2nd Edition), VHC Publishers, ISBN (Verlagsgesellschaft) 3-527-26954-1 (VHC Inc.) 0-89573-752-3, 1991.